

# exhibitor information pack ●●●



**exhibit**  
systems ●●●  
creative solutions for any event



Please read the following information carefully. This manual contains all the relevant information to assist you in the preparation of your display.

Should you have any questions or require further information on any of our products or services please contact us.

phone	+ 61 2 9982 5511
fax	+ 61 2 9982 9899
post	PO Box 801, Freshwater NSW 2096
premises	5 Boola Place, Cromer NSW 2099
email	<a href="mailto:sales@exhibitsystems.com.au">sales@exhibitsystems.com.au</a>
website	<a href="http://www.exhibitsystems.com.au">www.exhibitsystems.com.au</a>

## EXHIBITOR INFORMATION PACK

IEEE ICC 2014  
10-13 JUNE 2014  
LEVEL 3 – HILTON SYDNEY HOTEL



Official Contractor: Exhibit Systems Pty Ltd, PO Box 801 FRESHWATER NSW 2096  
PH +61 2 9982 5511 FAX +61 2 9982 9899  
Contact: Fiona Morris Email: fionam@exhibitsystems.com.au

## IMPORTANT INFORMATION FOR ALL EXHIBITORS

### EXHIBIT SYSTEMS HAVE BEEN APPOINTED AS THE OFFICIAL EXHIBITION BOOTH SUPPLIER FOR IEEE ICC 2014

The following information pack has been included to help you in the preparation of your exhibition stand. Please take time to read and understand what information is required from you. It is very important that we receive your completed forms **on time** to ensure availability.

Late orders are placed in the order they are received and dealt with in turn. Any orders onsite are subject to availability, time constraints and LATE PAYMENT CHARGES.

Venues across Australia require the compulsory testing & tagging of ALL electrical leads and appliances used in exhibitions. If equipment needs to be tested on-site there is a charge of \$31.00 per item + GST.

### Contents

- **MODULAR BOOTH PACKAGE**

Provides detail of the shell scheme system to be used and the inclusions in your booth package

- **UPGRADE OPTIONS**

A sample of options available to customise your display and make it stand out from the crowd!

- **FASCIA SIGNAGE FORM 1** – SHELL SCHEME booth exhibitors are to complete and return this form

- **POWER & LIGHTING FORM 2** – If you require additional power & lighting or you are a Space Only Exhibitor complete and return this form. Shell Scheme booth packages receive the following electrical allowance

SHELL SCHEME STAND SIZE	ELECTRICAL PACKAGE
3m x 2m	2 x track spots & 1 x power point
6m x 2m	4 x track spots & 2 x power points
9m x 2m	6 x track spots & 2 x power points

- **FURNITURE INCLUSIONS TO EACH SHELL SCHEME BOOTH**

3m x 2m	1x Bella bar table, 2 Stools, 1x Curved counter, 1x Trash bin
6m x 2m	1x Elite table, 4 Stools, 1x Curved counter, 1x Trash bin
9m x 2m	2x Elite table, 8 Stools, 1x Curved counter, 1x Trash bin

### If Exhibitors elect to have NO FASCIA – the TRACK LIGHTING IS REMOVED

- **CARPET & WALLING FORM 3** – If you require additional walling or wish to change colour or walling/carpet complete and return this form. The venue is already carpeted.
- **SHELVING FORM 4** – If you require shelving to be hung from the walls complete and return this form.
- **STAND LAYOUT FORM 5** – Sketch any stand placements / modifications to your booth and return this form

**DEAD LINE FOR ALL FORMS IS: FRIDAY 2<sup>nd</sup> JUNE 2014**

Late fees will be charged after the due date and all on-site orders have an additional 20% charge

# MODULAR BOOTH PACKAGE

IEEE ICC 2014  
 10-13 JUNE 2014  
 LEVEL 3 – HILTON SYDNEY HOTEL



Official Contractor: Exhibit Systems Pty Ltd, PO Box 801 FRESHWATER NSW 2096  
 PH +61 2 9982 5511 FAX +61 2 9982 9899  
 Contact: Fiona Morris Email: fionam@exhibitsystems.com.au

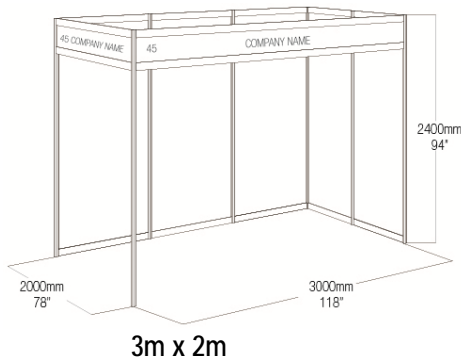

3m x 2m

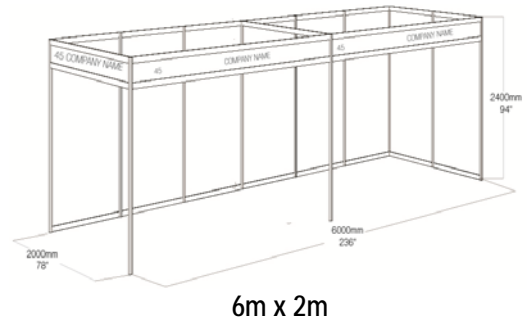

6m x 2m

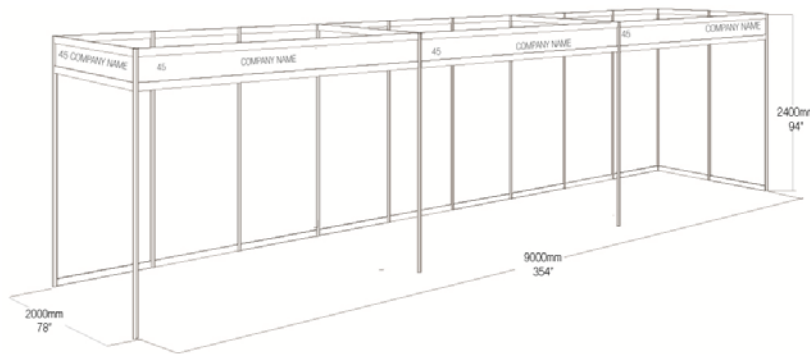

9m x 2m

The following is included in your shell scheme stand:

- FASCIA SIGNAGE** A 220mm high **WHITE** panel with 90mm high **BLACK** vinyl cut lettering in Arial font. Fascia signs are provided to all open sides with the longest size being 4m and posts dividing longer fascia sizes.
- WALLS** The walls are **GREY** for this event. NO nails, screws or glue are to be used to fix to the panels, please use **VELCRO** to adhere to the walls. The panels are temporary hire stock and any damage to them during the show will be charged at \$275.00 per panel.
- FLOORING** The Venue is already carpeted.
- POWER & LIGHTING** Electrical inclusions vary according to your stand size.

SHELL SCHEME STAND SIZE	ELECTRICAL PACKAGE
3m x 2m	2 x track spots & 1 x power point
6m x 2m	4 x track spots & 2 x power points
9m x 2m	6 x track spots & 2 x power points

IF EXHIBITORS ELECT TO HAVE NO FASCIA THEN THE TRACK LIGHTING IS ALSO REMOVED







# CARPET & WALLING FORM 3

IEEE ICC 2014  
10-13 JUNE 2014  
LEVEL 3 – HILTON SYDNEY HOTEL

TO BE COMPLETED FOR  
COLOUR CHANGES OR  
EXTRAS IF REQ'D



Official Contractor: Exhibit Systems Pty Ltd, PO Box 801 FRESHWATER NSW 2096  
PH +61 2 9982 5511 FAX +61 2 9982 9899  
Contact: Fiona Morris Email: fionam@exhibitsystems.com.au

COMPANY NAME & ADDRESS:

CONTACT NAME:		EMAIL:	
PHONE NUMBER:		FAX NUMBER:	
DATE:		STAND NUMBER:	

The standard wall colour is **GREY**. The Venue is already carpeted.

If you wish to change colours of carpet / walling or you require additional please complete form below. Prices include installation

This form will be a Tax Invoice once payment is made: ABN 78 091 935 116

Option	Code	Colour	Price	Qty	Total
<input type="checkbox"/> Walling		Black	\$56.00 per lineal metre		\$
		Red	\$56.00 per lineal metre		\$
		Blue	\$56.00 per lineal metre		\$
		White	\$56.00 per lineal metre		\$
<input type="checkbox"/> Flooring (Raised – 32mm)	071901	White	\$78.00 per square metre		\$
	071904	Beech	\$89.00 per square metre		\$
<input type="checkbox"/> Carpet Includes compulsory baseboard	072003	Red	\$39.00 per square metre		\$
	072005	Blue	\$37.00 per square metre		\$
	072002	Black	\$35.00 per square metre		\$
	072010	Teal (Green)	\$35.00 per square metre		\$
	072009	Charcoal grey	\$35.00 per square metre		\$
	072011	Bright colours	\$94.00 per square metre		\$

**ALL ORDERS PLACED AFTER MONDAY 2<sup>nd</sup> JUNE 2014 INCUR A COMPULSORY LATE FEE \$ 60.00**

Please notify our staff onsite of any disparity to your order No claims will be recognised after the event	<b>SUB-TOTAL</b>	\$
	<b>DAMAGE WAIVER 7% SUB-TOTAL</b>	\$
	<b>CARTAGE FEE 20% SUB-TOTAL (min. \$50)</b>	\$
	<b>10% GST</b> Calculated on subtotal + d/w + cartage	\$
	<b>FINAL TOTAL INCLUDING GST</b>	\$

**TERMS OF PAYMENT: Full Payment MUST accompany this order or work will not be carried out**

*Tick appropriate box*

CHEQUE     DIRECT DEPOSIT - St George Bank, Kogarah    BSB 112 879    A/C no 065930031    SWIFT SGBLAU2S

VISA     MASTERCARD     DINERS     AMEX

Account Name                         Expiry Date   /

Credit Card No                         Amex Pin / CSV

Signed .....ORDER NOT VALID UNLESS SIGNED BY HIRER (AUTHORISED AGENT/ CARD HOLDER)

**CREDIT CARD ORDERS WILL INCUR A 3% SURCHARGE**

# SHELVING FORM 4

IEEE ICC 2014  
 10-13 JUNE 2014  
 LEVEL 3 - HILTON SYDNEY HOTEL

TO BE COMPLETED IF YOU  
 REQUIRE SHELVING ON  
 YOUR WALLS



Official Contractor: Exhibit Systems Pty Ltd, PO Box 801 FRESHWATER NSW 2096  
 PH +61 2 9982 5511 FAX +61 2 9982 9899  
 Contact: Fiona Morris Email: fionam@exhibitsystems.com.au

COMPANY NAME & ADDRESS:

CONTACT NAME:		EMAIL:	
PHONE NUMBER:		FAX NUMBER:	
DATE:		STAND NUMBER:	

This form will be a Tax Invoice once payment is made: ABN 78 091 935 116

Description / Item	Qty	Price	Total
Shelving Set (3 shelves per set)		@ \$140.00 each	\$
Additional Extra / Shelves - angled		@ \$ 46.00 each	\$
Additional Extra/ Shelves - straight		@ \$ 46.00 each	\$
<b>ALL ORDERS PLACED AFTER MONDAY 2<sup>nd</sup> JUNE 2014 INCUR A COMPULSORY LATE FEE</b>			<b>\$60.00</b>
Please notify our staff onsite of any disparity to your order No claims will be recognised after the event	SUB-TOTAL		\$
	DAMAGE WAIVER 7% SUB-TOTAL		\$
	CARTAGE FEE 20% SUB- TOTAL (min \$30)		\$
	10% GST Calculated on subtotal + d/w + cartage		\$
	<b>FINAL TOTAL INCLUDING GST</b>		\$

Shelves are hung from the wall only and are White

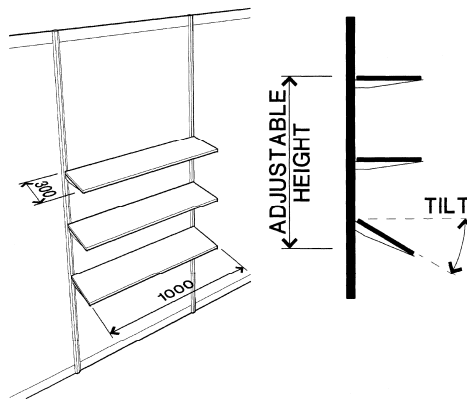

\$140.00 per set + \$46 for each additional shelf

TERMS OF PAYMENT: Full Payment MUST accompany this order or work will not be carried out

Tick appropriate box

CHEQUE     DIRECT DEPOSIT - St George Bank, Kogarah BSB 112 879 A/C no 065930031 SWIFT SGBLAU2S

VISA     MASTERCARD     DINERS     AMEX

Account Name                      Expiry Date   /

Credit Card No                     Amex Pin / CSV

Signed .....ORDER NOT VALID UNLESS SIGNED BY HIRER (AUTHORISED AGENT/ CARD HOLDER)

**STAND LAYOUT FORM 5**

TO BE COMPLETED ONLY  
FOR PLACEMENT  
CLARIFICATION



IEEE ICC 2014  
10-13 JUNE 2014  
LEVEL 3 - HILTON SYDNEY HOTEL

Official Contractor: Exhibit Systems Pty Ltd, PO Box 801 FRESHWATER NSW 2096  
PH +61 2 9982 5511 FAX +61 2 9982 9899  
Contact: Fiona Morris Email: [fionam@exhibitsystems.com.au](mailto:fionam@exhibitsystems.com.au)

**CREDIT CARD ORDERS WILL INCUR A 3% SURCHARGE**

**COMPANY NAME & ADDRESS:**

CONTACT NAME:

EMAIL:

PHONE NUMBER:

FAX NUMBER:

DATE:

STAND NUMBER:

Please draw the layout of your stand showing locations of power, lighting, walling and any other modifications you are making, or, attach a copy of your plans if available.

**Back of Stand**

**Front of Stand**